

# Stelvio

Modular converting machine highly configurable,  
from blank die cut production to high quality  
label embellishment

## MAIN FEATURES

- BOSCH REXROTH electronics, servo drive motors on nip roll and rewinders
- Servo driven 800mm unwinder with Energy recovery, for a significant cost saving
- Webguide with ultrasonic sensor and movable splicing table with pneumatic clamps
- Full rotary die cut to register with +/- 15mm lateral adjust
- servo driven matrix rewriter with diameter sensor and matrix rupture sensor
- Mechanical speed up to 150m/min
- Display 12" color touch screen with step by step instructions
- Storable job recipes with quick recall by name, customer and favourites
- Remote service and production data export
- Stop production with label counter, length and final diameter
- Automatic stop at unwinder end of roll
- Ultrasonic label counter
- 2 in 1 slitting system, to pass from rotary to razor in few minutes with no additional devices
- Rewinder with servo drive motorization
- Available size 330mm, 430mm

## AVAILABLE OPTIONS

- Semi rotary die cut module
- Third part magnetic cylinder compatibilità
- Anvil fine adjust with pressure gauge indicators
- Flexo station for varnish and print to register
- Cold foil unit
- PRINT BAR for digital screen printing
- Quality control camera
- Inkjet marker for variable data, datamatrix etc
- LAVAREDO automatic slitter positioning system for both rotary and razor
- Second rewriter with independent servo drive motorization
- Semi automatic turret rewriter VAJOLET
- Corona treatment

# Stelvio

Soluzione modulare  
per convertire etichette  
autoadesive

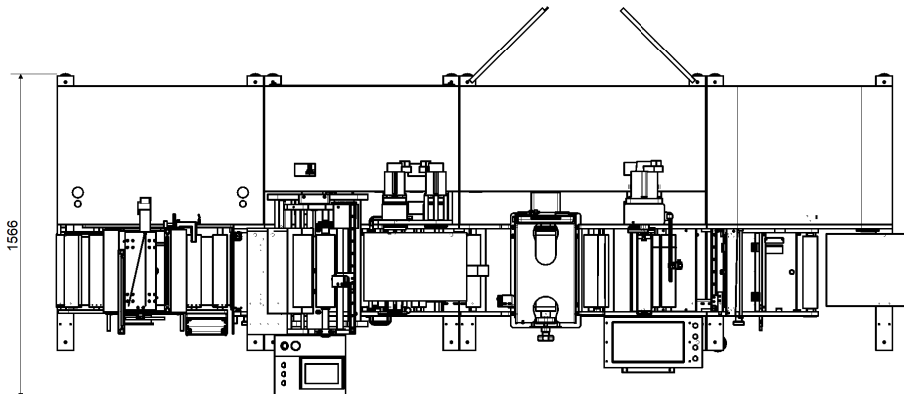
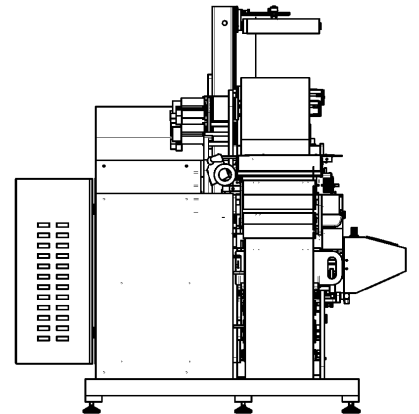
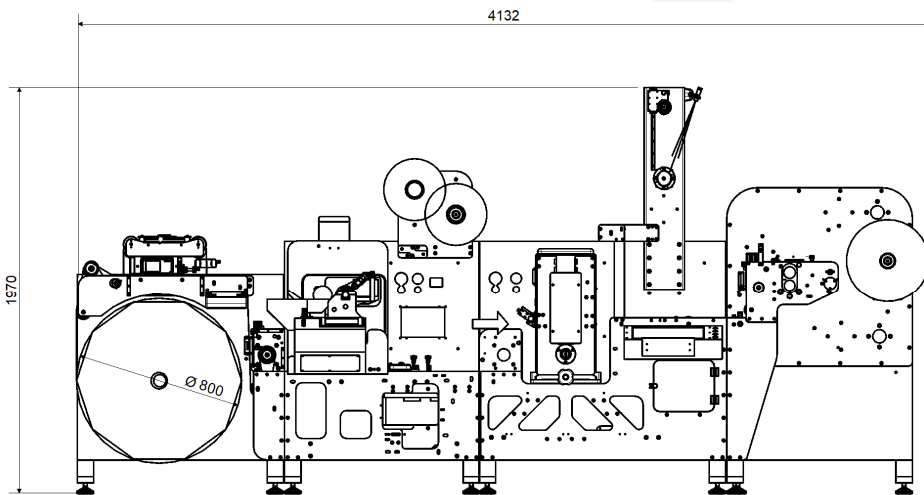
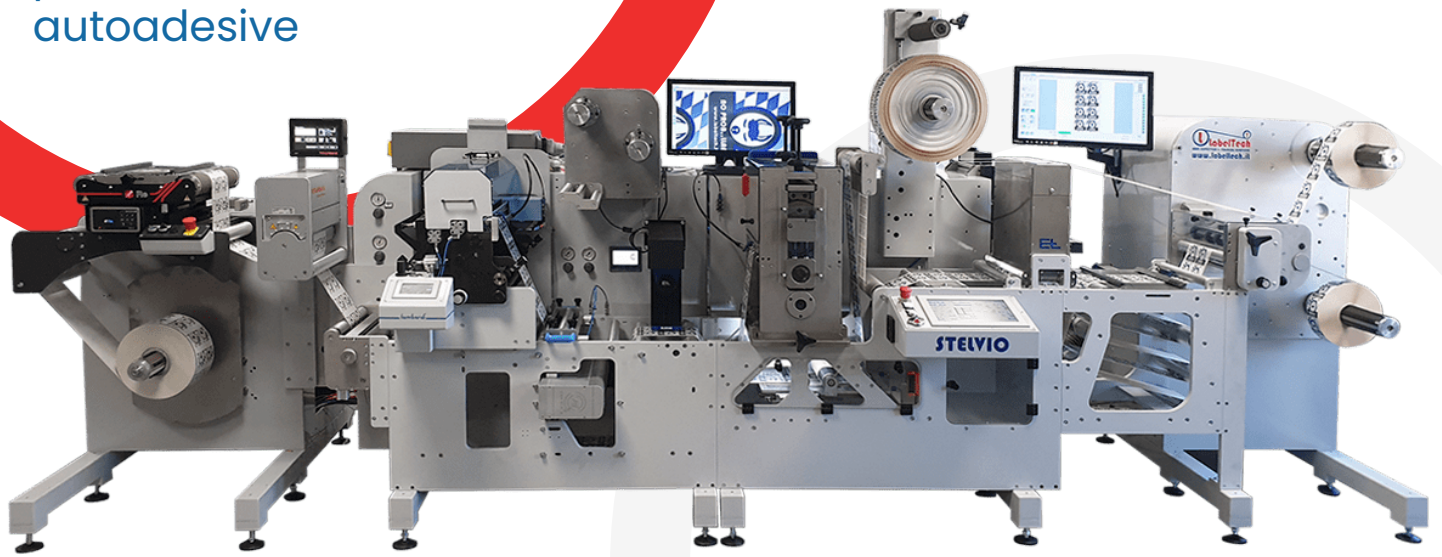

**Labeltech sas** di Gabriele D'Onofrio & C.  
Via per Turbigo, 17 - 20022 Castano Primo (MI) Italy  
Tel. +39 0331 882289 · info@labeltech.it [labeltech.it](http://labeltech.it)

